

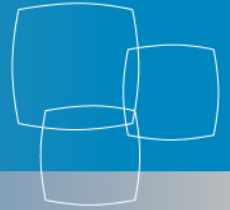

Industry
Canada

Industrie
Canada

Public Safety and Radio Frequency Spectrum



Presentation to:
**National Public Safety
Telecommunications Council**

Arlington, VA

June 16-18, 2008



Canada 



Outline

- **Spectrum Management in Canada**
- **Canada - U.S. Considerations**
- **IC Role in Public Safety Radiocommunication**
- **Discussion on Spectrum used by Public Safety in Canada**
- **Radio Interoperability**





Managing Spectrum

- Technical Rules make up the foundation of spectrum management, because the laws of physics first dictate spectrum sharing conditions.
- There's no free lunch...Frequency, distance and power are all tied together in a complex manner.



each service has its own color





Frequency Planning



- **Begins with international planning at the ITU**
 - Frequencies are allocated to radio services internationally by the International Telecommunication Union (ITU)
- **Allocations define a permitted use**
 - Users are classified into categories (e.g. Mobile, Fixed, Amateur, Maritime etc.)
 - Facilitates the administration of the authorization process
- **IC then develops appropriate legislation, regulations, policies and standards so that the spectrum is used to best serve Canadian interests and needs**





IC Spectrum Management Process

- **Technical rules and procedures are developed for the use of allocations**
- **Licensing is carried out in accordance with policy and technical rules**
 - Radio Equipment Certification standards
 - Frequency Allocation
 - Radio Frequency Band Planning
- **Frequencies are assigned by:**
 - First-come, first served
 - Competitive process (Only if demand exceeds supply, comparative review and auction)
- **Licence exempt devices:**
 - No fee / no protection (e.g. Wi-Fi, garage door openers)
- **Licensed:**
 - Fee / Interference managed (e.g. cellular, two-way radio)





Spectrum Management Offices across Canada

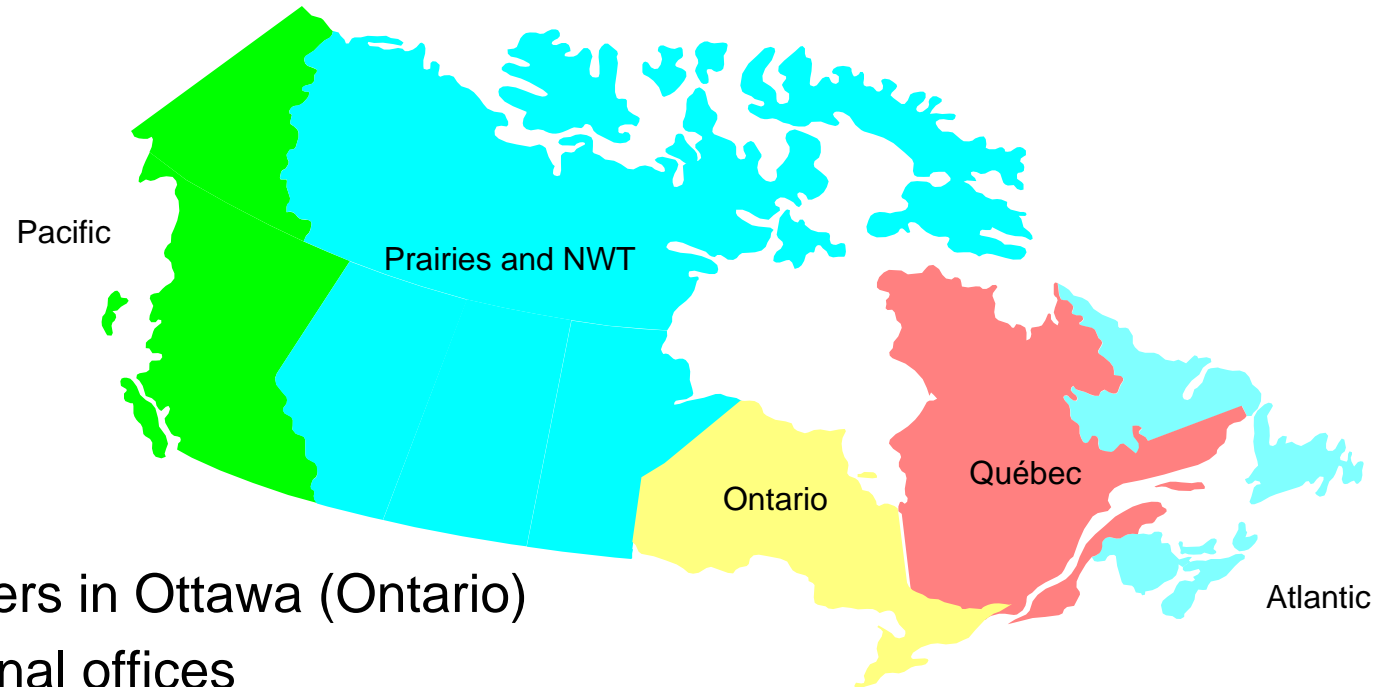

- Headquarters in Ottawa (Ontario)
- Five Regional offices
- Twenty District offices
- Fourteen Branch or Sub offices





Our Public Domain

- <http://www.ic.gc.ca/spectrum/>

The screenshot shows the Industry Canada website interface. At the top left is the Canadian flag and the text "Industry Canada / Industrie Canada". At the top right is the "Canada" logo. The main header features a blue banner with a globe, a red maple leaf, and the text "Industry Canada ic.gc.ca". Below the banner is a navigation bar with links for "Français", "Home", "Contact Us", "Help", "Search", and "canada.gc.ca". The main content area is titled "Spectrum Management and Telecommunications" and includes a "In the News" section with several news items. On the left is a sidebar menu with various navigation options. On the right is a "Quick Links" section with "Spectrum Auctions", "Amateur Radio Service", and "Spectrum Direct" links.

Industry Canada
ic.gc.ca

Industry Canada > Radio, Spectrum and Telecommunications > Spectrum Management and Telecommunications

Spectrum Management and Telecommunications

In the News

- [Government of Canada Opens up Wireless Industry to more Competition](#) (News Release) **NEW**
- [Auction of Spectrum Licences for Advanced Wireless Services and Other Spectrum in the 2 GHz Range](#)
 - [Round by Round Results of AWS Auction](#) **NEW**
 - [Qualified Bidders' Names and Numbers](#) (Updated May 28, 2008)
- [Industry Canada Arbitration Rules and Procedures \(Draft\)](#) **NEW**
- [Fees for Spectrum in the Radio Frequency Band 4940-4990 MHz for Broadband Public Safety Communications](#) **NEW**
- [Extension to the Comment Period for the Consultation on the Renewal of 24 and 38 GHz Spectrum Licences and Spectrum Licence Fees for 24, 28 and 38 GHz](#)

Industry Canada Feature

[Industry Canada 2008-2009 Business Plan](#)
Industry Canada's strategic objectives, workforce renewal and corporate priorities for 2008-2009.

Stay informed! [Receive newsletters and email updates.](#)

Quick Links

Spectrum Auctions

Amateur Radio Service

Spectrum Direct®
<http://spectrumdirect.ic.gc.ca/>





Spectrum Direct



Canada 

Français	Contact Us	Help	Search	Canada Site
Home	Site Map	What's New	About Us	Registration

strategis.gc.ca

Effective January 19, 2008, Industry Canada has converted all radio station licences and broadcast certificates to the NAD-83 standard. All reports and files produced by the Department now follow this standard. ([Details...](#))

To determine if your licence was affected by this change, [click here](#).

- Spectrum Management
- ## Spectrum Direct®
- On this page:**
- Account Information
 - Licence Applications
 - Broadcasting Applications
 - Radio Frequency Search
 - Invoices
 - Web Profile
 - PCS/Cellular Stations
 - Maritime Information
 - Online Help
 - Related Sites

- Important Notices**
- [Required Software](#)
 - [Common Problems](#)
 - [Security](#)
 - [What's New](#)

You are here: Main Menu

Account Information

- [Virtual Licence](#) | [Land Station Browser](#)  | [Mobile Station Browser](#)  | [Invoice Browser](#) 

Use the Virtual Licence system to find, download, and print a copy of your radiocommunication licences. The Land Station Browser, Mobile Station Browser, and Invoice Browser allow you to browse and search all administrative, technical, and financial information about the radio licence accounts associated with your [Web profile](#).

[▲ Top of page](#)

Licence Applications

- [Land Mobile Application \(frames\)](#) / [\(no frames\)](#)  | [Microwave Application \(frames\)](#) / [\(no frames\)](#) 
- [Application Utilities](#) | [XML Resources](#)

Use the Land Mobile Application or Microwave Application forms to apply for licences on line. Application Utilities allow you to add to the radio model or antenna model lists, or download application-related software.

- On-Line Database shows 90% of Canadian users



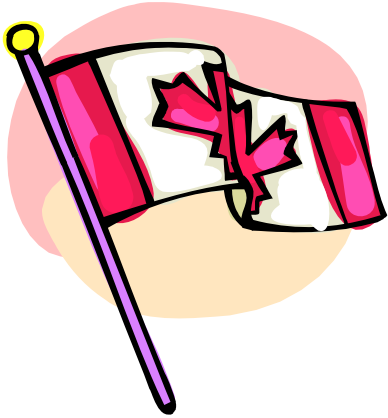

Canada-U.S. Considerations





Canadian Population Density

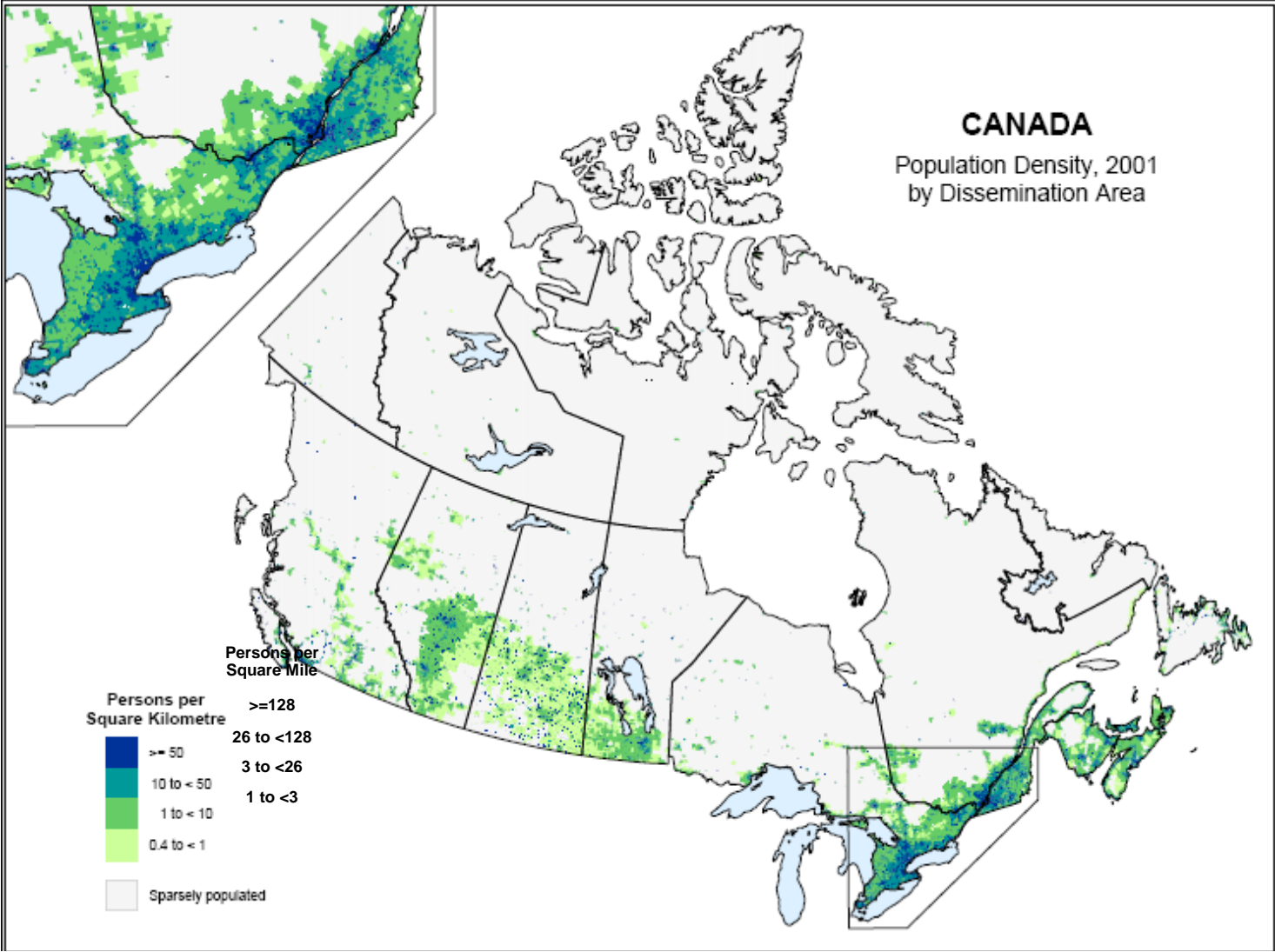

Source: 2001 Census of Canada. Produced by the Geography Division, Statistics Canada 2002.





Canada – U.S. Considerations

- **80% of Canada's population resides within 120 km of the border**
 - This includes some of our largest cities i.e. Vancouver, Montreal, Toronto
- **Radio waves don't stop at the border...We share the use of the radio spectrum**

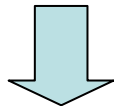
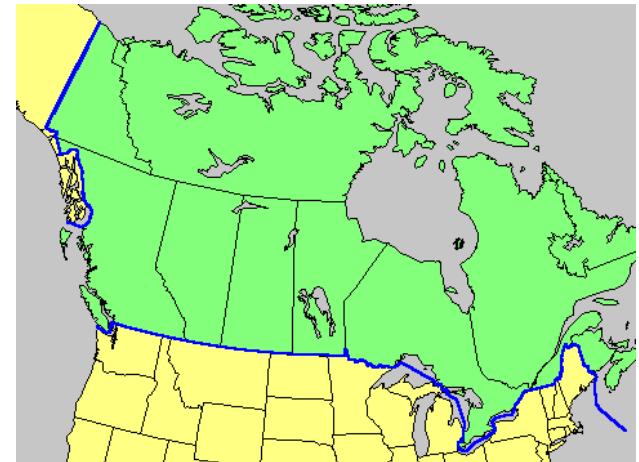

Coordination: The act of exchanging information with, and gaining the consent of, another entity (usually another country), in an effort to ensure harmful interference is not caused to or received from radio stations of that entity





Canada/US Above 30 MHz Coordination Agreement¹

- **Originally signed in 1962 and revised in 1965**
- **Arrangement A, between FCC and IC, developed under this agreement covers many VHF and UHF bands**
 - This is a First Come First Served (FCFS) Arrangement
 - No channel plan or reserved frequencies
 - Exchange of technical information and comments between FCC and IC

1) EXCHANGE OF NOTES BETWEEN THE GOVERNMENT OF CANADA AND THE GOVERNMENT OF THE UNITED STATES OF AMERICA CONCERNING THE COORDINATION AND USE OF RADIO FREQUENCIES ABOVE THIRTY MEGACYCLES PER SECOND





Bilateral Coordination Approaches

- **First Come, First Serve (FCFS)**
 - The country wishing to install a station within the coordination zone (approx. 120 km from border) provides station information to other country
 - This technical information is analyzed and a determination is made with respect to the potential for harmful interference to existing radio stations
 - A response is provided to the originating administration
 - Only existing stations can be protected from potential interference
- **Block and Zone**
 - Each country has specific spectrum to use in specific areas
 - Coordination is not usually required to use your own spectrum
 - Often use of other administration's spectrum is permitted subject to meeting specific technical criteria
 - Exchange of technical information is generally not required
- **Licencee to Licencee with technical provisions (e.g. PFD)**
 - Both countries have access to all spectrum provided they meet technical provisions in border area
 - If technical provisions not met, licensees on each side of border coordinate use with each other





Analysis for FCFS Arrangements

- **Performed by local IC spectrum management offices**
 - Experience in frequency analysis
 - Aware of local terrain, clients
 - Individual analysis done on each proposal
- **Based on sound engineering practices**
 - Similar to procedures used by FCC
- **Terrain based propagation models**





Coordination Proposal Volumes

- Average turn-around time for U.S. proposals is approximately 35 days

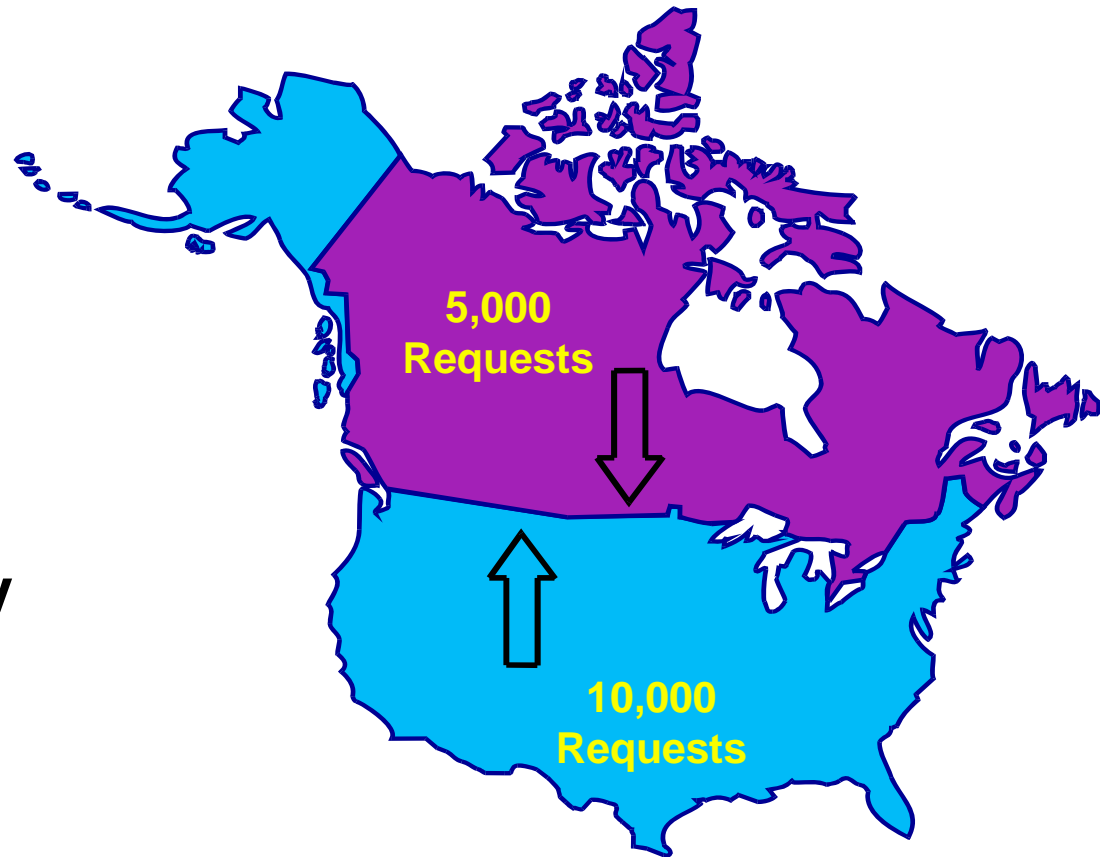



Items of Interest

- **Treaty**

- Has worked for over 40 years with over 15,000 transactions per year
- Arrangement A
 - Flexible enough to accommodate changes such as:
 - Refarming/narrowbanding
 - New technologies (e.g. digital)
 - New uses (e.g. data)
 - Increased demand for VHF and UHF (400 MHz) spectrum
 - Movement of users (i.e. changing frequencies; adding capacity, etc.)
 - Facilitates use of the spectrum through analysis of individual proposals and ability to perform on-air tests
- Other Arrangements
 - Developed through regular (3x/year) meetings with the FCC
 - Accommodates other approaches such as block and zone and pfd (e.g. Arrangements F and G)
 - FCC have agreed to make available draft versions of 7 new Arrangements on a provisional basis while ratification process is on-going (<http://www.ic.gc.ca/epic/site/smt-gst.nsf/en/sf01238e.html>)





Items of Interest (cont'd)

- **\$\$\$\$**
 - No money comes to IC
- **Time**
 - 35 day average turn around time is very good
- **Proposal evaluation**
 - Proposal evaluation is not arbitrary
 - Each proposal reviewed on individual basis
 - Analysis based on sound engineering practices
 - Only existing Canadian users are protected
- **Canadian licensees**
 - Use of on-line database will show most Canadian users
 - Canadian station location, coordinates, frequency and call sign information are included in replies





Discussion on Spectrum and Public Safety in Canada





What does Industry Canada do for Public Safety?

- **Consult on the best use of the spectrum**
- **Manage the radio spectrum**
- **Designate frequencies for public safety**
- **Create standards and guidelines that facilitate radio interoperability**
- **Facilitate global and regional harmonization**





Public Safety

- **Public safety services are services involving safety of life and property**
- **IC recognizes the following hierarchy of safety service providers:**
 - Category 1: Police, fire and emergency medical services
 - Category 2: Forestry, public works, public transit, dangerous chemical clean-up, customs and other agencies contributing to public safety
 - Category 3: Other government agencies and certain non-government agencies





Spectrum Used by Public Safety in Canada

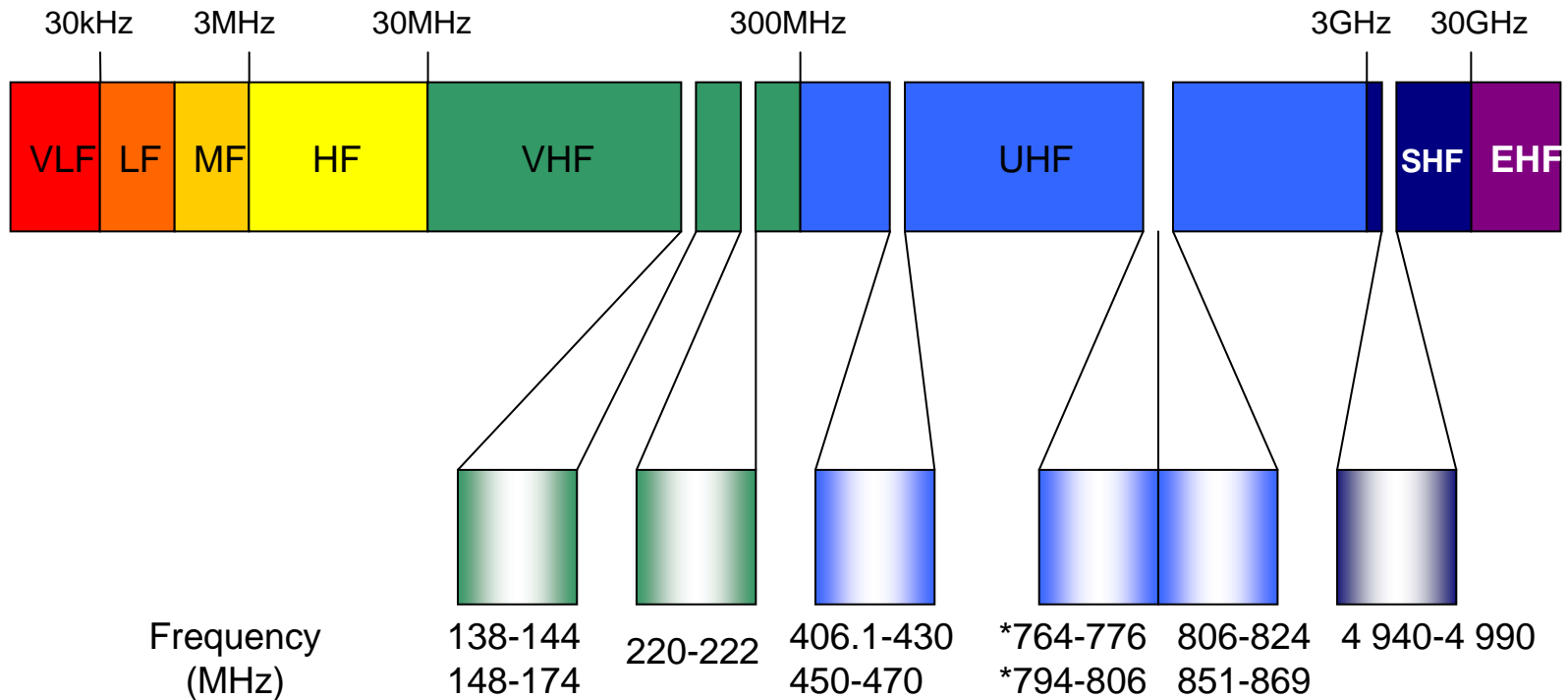

* Under Consultation





VHF (138-174 MHz Band)

- Excellent propagation properties
- Readily available and affordable equipment
- Heavily used by public safety

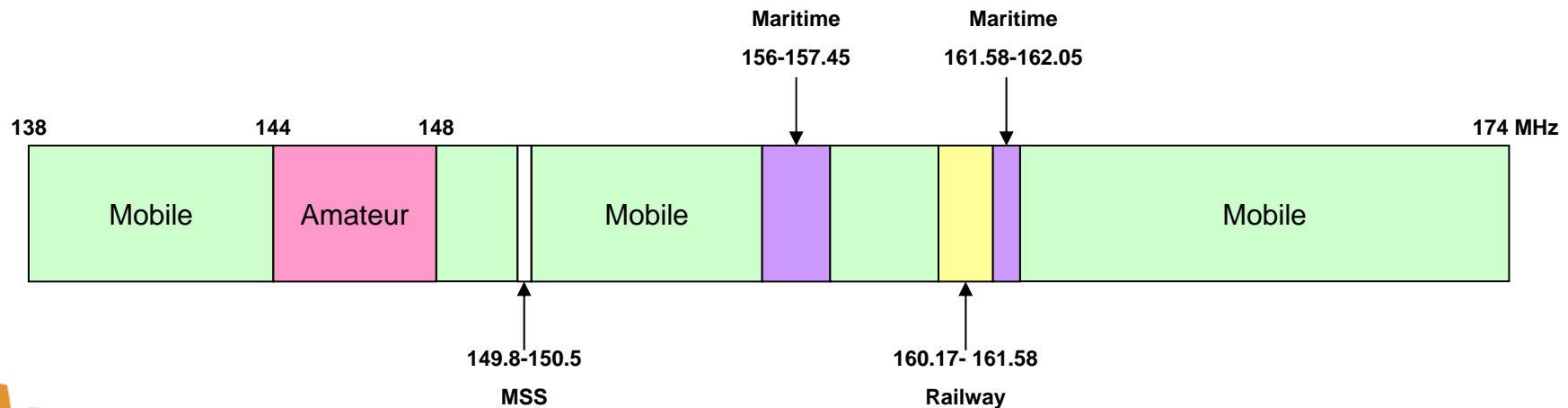



VHF Challenges

- **First national band plan published in 2004 but band has been in use since the 50's**
- **Channeling not aligned with the US**
- **Used by many different types of licensees including municipal/provincial gov't, construction, delivery companies etc.**
- **Public Safety is all over the band; No designated frequencies for public safety**
- **Will continue to be used in this manner for the foreseeable future**





Example of Stations (Fixed and Base) in lower VHF Band

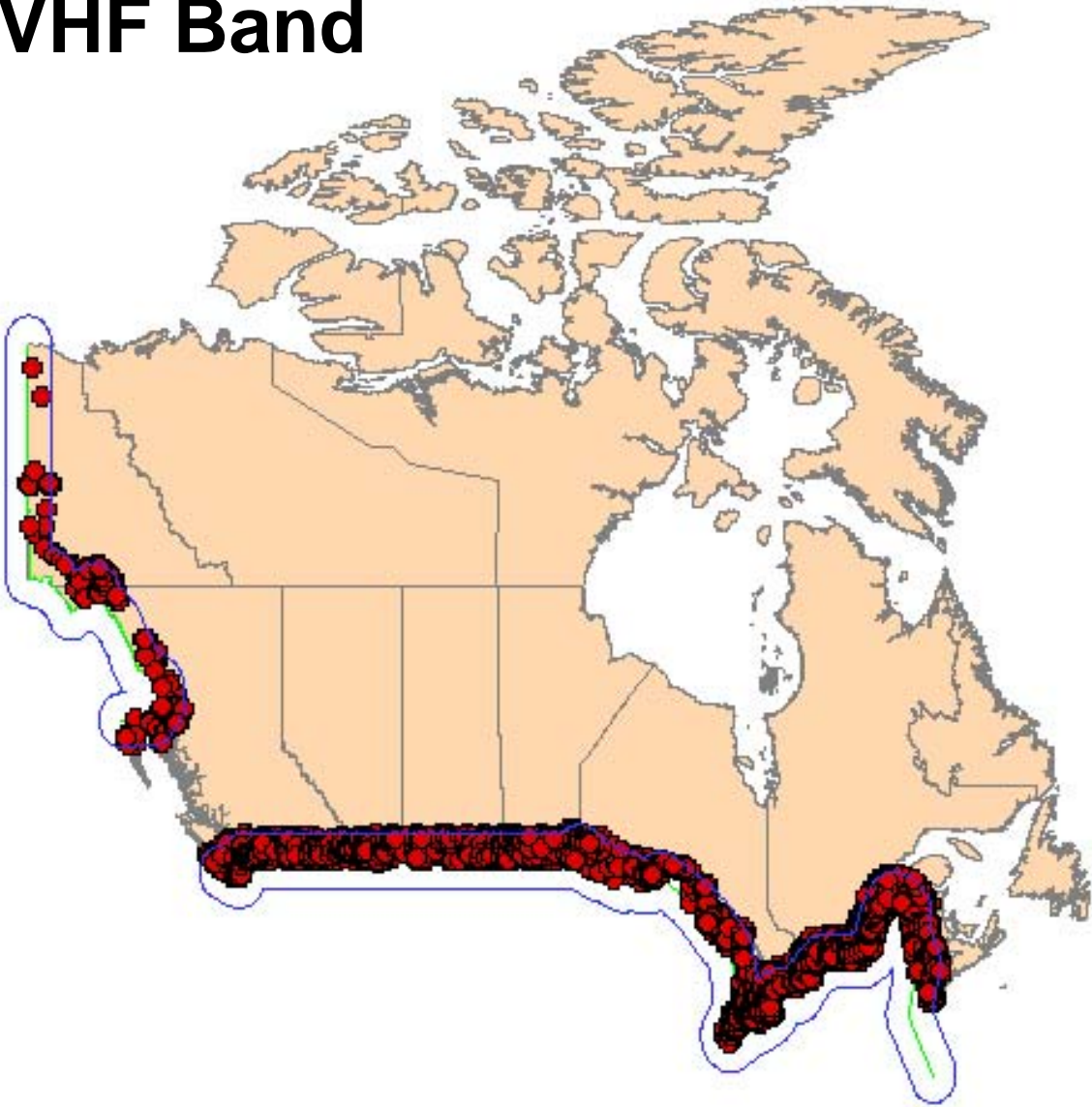



Example of disparity of Public Safety in the VHF band

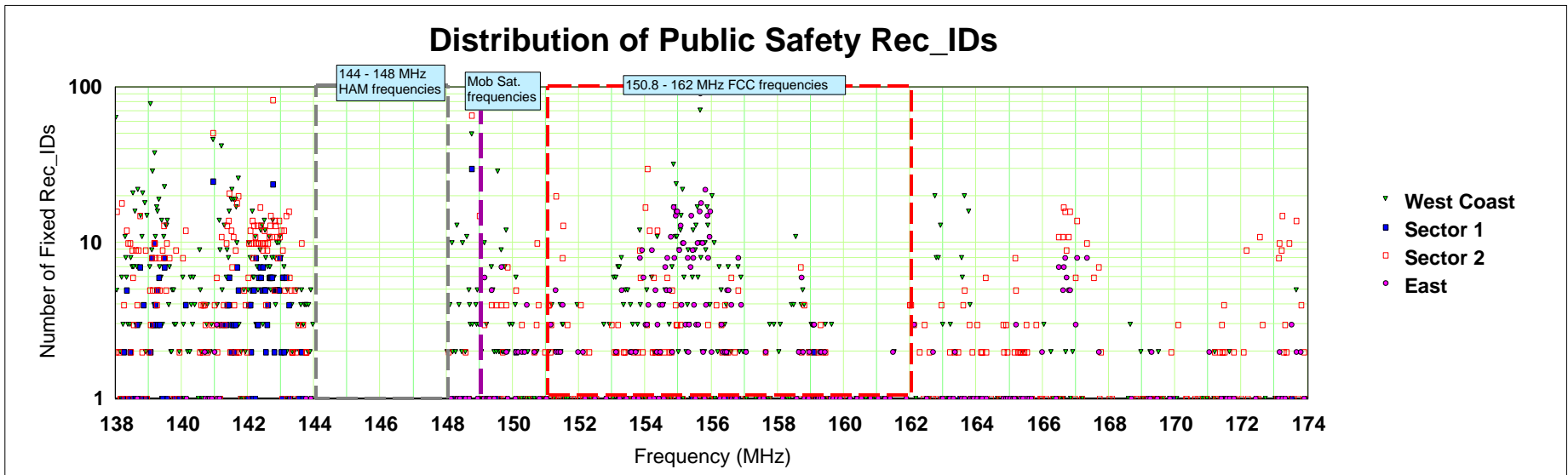



UHF

- The bands 406.1-430 MHz and 450-470 MHz
- More organized than the VHF
- Excellent propagation
- Heavily used by public safety

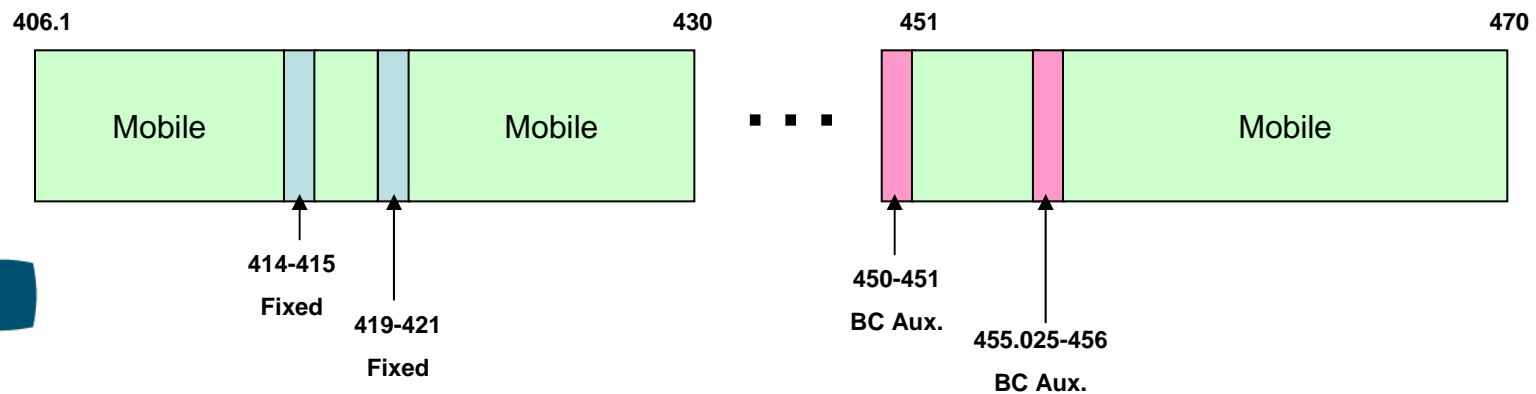



Redeployment Plan

- **Also called “refarming” or “narrowbanding”**
- **Applies to the VHF and UHF band only**
 - 138-174 MHz
 - 406.1-430 MHz and 450-470 MHz
- **Phase 1**
 - Equipment must go from bandwidths of 25/30 kHz to 12.5/15 kHz
 - *Ongoing*
- **Phase 2**
 - Equipment must go from bandwidths of 12.5/15 kHz to 6.25/7.5 kHz
 - *Date?*
- **Applies to areas of high spectrum congestion**
 - Discretion of the regional offices



<http://www.ic.gc.ca/epic/site/smt-gst.nsf/en/sf01654e.html>



700 MHz

- **Consultation published on January 19, 2008**
 - Deals only with the Narrowband/ Wideband Public Safety in 700 MHz
 - Broadband public safety is subject to a future consultation
 - Elements of the consultation paper:
 - Designation of the TV channels 64 and 69 for public safety
 - Proposed new band plan
 - Transition from the old band plan to the new band plan
 - Continuation of the use of wideband systems
- Received 28 Comments
 - Public safety agencies; Provinces and municipalities
 - Broadcasters
 - Manufacturers

Proposed Canadian Band Plan

60	61	62	63	64	65	66	67	68	69		
Future Consultation			Public Safety				Future Consultation			Public Safety	
			A*	B	NB 6 MHz	C				A*	B

NB – Narrowband

* Block A will be Subject to a future consultation that would look at harmonizing with the U.S. with respect to the broadband designation in the bands 763-768 MHz and 793-798 MHz.





700 MHz – Consultation Responses on Proposals

Designation and Band Plan

- Strongly supported

• Transition Plan

- General agreement
- Proper planning will be essential by PS entities to accommodate the effort, cost associated with retuning
- Some discussion on timing

• Wideband options and the amount of wideband

- Most support to aggregate the NB channels
- Support for using blocks B and C in areas where there is no broadband
- Concern expressed that the use of NB voice is not limited
- Proposals for 3+3 MHz of wideband
- Allow regional flexibility



Comments and paper available at:

<http://www.ic.gc.ca/epic/site/smt-gst.nsf/en/sf08934e.html>



800 MHz - Situation in Canada

- No specific designation based on the category of services, therefore no interleaved plans
- Technical rules
 - Assignment of spectrum following EMC analysis
 - Lower operating power levels
- **Interference to PS systems: not a major issue for Canada at this time**

Canada Plan



New U.S. Plan

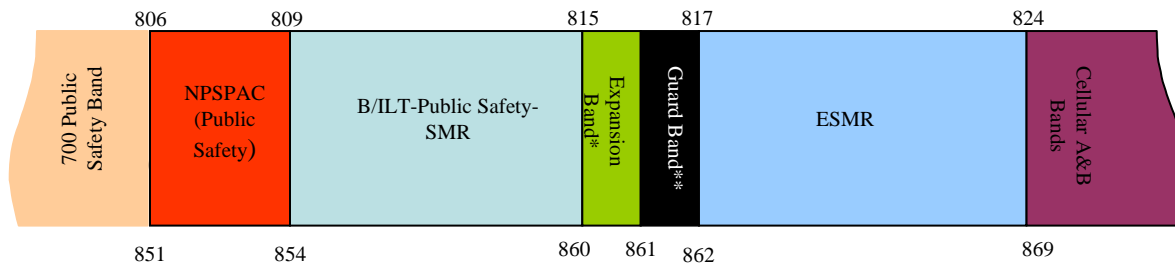



4.9 GHz

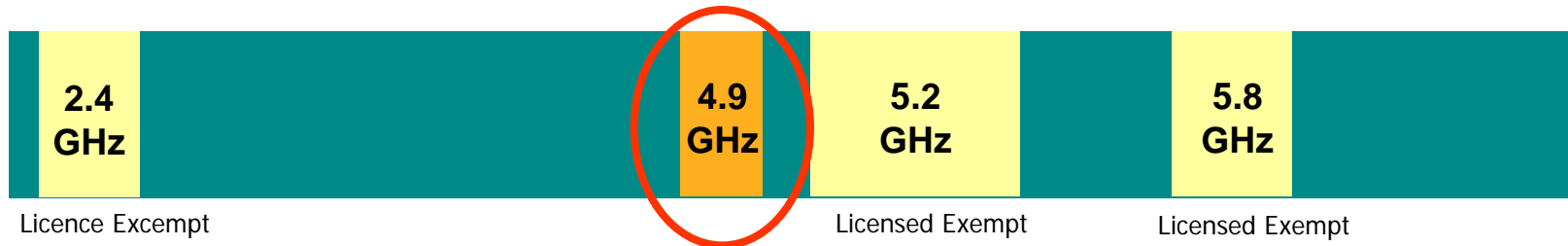

- **June 2006: Department released new Spectrum utilization policy**
<http://strategis.ic.gc.ca/epic/internet/insmt-gst.nsf/en/sf08666e.html>
- **Examples of potential applications might include:**
 - point-of-presence (i.e. “hot spot”) operations such as wireless high-speed file transfers from emergency sites to mobile units (less than 1 km radius)
 - Real-time video to and from mobile platforms
 - High quality imaging such as mug-shots, fingerprints, building layouts, maps
 - Database access
 - Temporary fixed links or backhaul communication links
- **Existing commercial-off-the-shelf (COTS) equipment from the 5 GHz band may be modified, reducing costs**
 - Key challenge may be finding applications



Mobile Broadband?



Interoperability

- **Challenge:**
Interoperability for first responders:
 - Incident Management
 - Infrastructure
 - Radio
- **Industry Canada consultation paper:**
 - Guidelines to advance the issue of radio-interoperability between public safety users

Many pieces needed to ensure interoperability happens

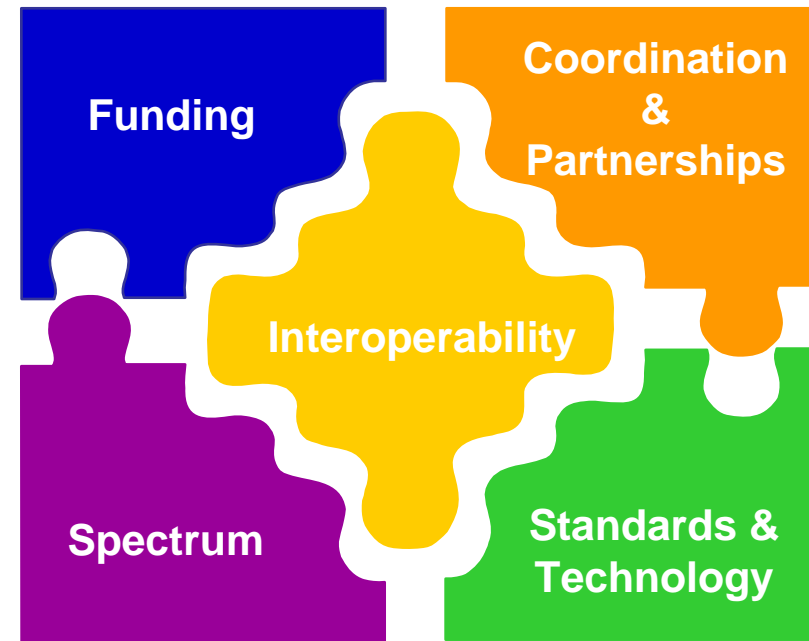

Public safety community must work together to plan, share and coordinate their common spectrum needs to facilitate emergency communications





Radio Interoperability Consultation

- **Consultation paper on Radio-Interoperability Guidelines**
<http://www.ic.gc.ca/epic/site/smt-gst.nsf/en/sf08632e.html>
 - directed towards the first responder community (ie: police, fire, ambulance)
 - definition of radio-interoperability and terminology
 - outline different levels of radio-interoperability
- **19 responses received which were generally supportive of the proposals**
- **Final decision to be released fall 2008**





IC work

- **Continue to examine ways to improve access to all spectrum in the border areas**
- **Challenges:**
 - FCFS bands are like a hotel
 - Where frequency bands are congested, there are limitations (e.g. no clear national VHF frequencies available)
 - Changes to current Arrangements would likely require licensees to be relocated or displaced
 - Lengthy process
 - Dependant on available replacement frequencies
- **Continue to work with FCC on bilateral issues**





Conclusion

- **VHF and UHF bands are heavily used and congested on both sides of the border**
- **Use of Canadian on-line database can provide an early indication of frequency use in Canada**
- **IC will continue to work together with FCC**





Questions?





Thank you

For more information, be sure to
visit our Internet website:

<http://sitt.ic.gc.ca>

Jennifer Wharram

Spectrum Engineer,
Spectrum Engineering Branch

Tel: (613) 990-4721

wharram.jennifer@ic.gc.ca



Canada 